

Entry Line Ethernet VDSL Extender User's Manual



Preface

This manual describes how to install and use the Hardened VDSL Ethernet Extender. The Hardened VDSL Ethernet Extender introduced here provides one channel for Ethernet over VDSL.

The Hardened VDSL Ethernet Extender fully complies with IEEE802.3 10Base-T and IEEE802.3u 100Base-TX/FX standards.

In this manual, you will find:

- Product overview
- Features on the Hardened VDSL Ethernet Extender
- Illustrative LED functions
- Installation instructions
- Specifications

Table of Contents

Preface	1
Table of Contents	3
Introduction	4
Product Overview	4
Product Features	4
Packing List	4
One-Channel Hardened VDSL Ethernet Extender	5
Ports	5
VDSL Mode Settings	5
DIP switch	5
Front Panel & LEDs	6
Installation	7
Selecting a Site for the Equipment	7
DIN Rail Mounting	7
Connecting to Power	8
Specifications	9

Introduction

The Hardened VDSL Ethernet Extender provides one channel for Ethernet over VDSL. This Hardened VDSL Ethernet Extender solution is perfectly fitted in the industrial applications or rugged environment.

Product Overview

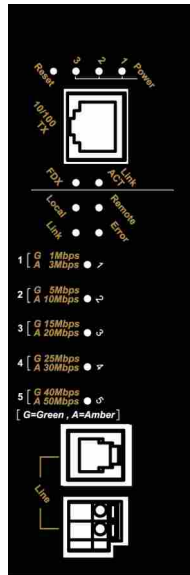

Product Features

- Meets NEMA TS1/TS2 Environmental requirements such as temperature, shock, and vibration for traffic control equipment
- Meets IEC61000-6-2 EMC Generic Standard Immunity for industrial environment
- Operates transparent to higher layer protocols such as TCP/IP
- Ethernet Port: Supports IEEE802.3/802.3u/802.3x. Auto-negotiation: 10/100Mbps, full/half-duplex; Auto MDI/MDIX
- VDSL port: Symmetrical on the VDSL, high-speed full-duplex 50Mbps communications link over existing copper telephone line
- One DIP switch for configuring Local (Loc) and Remote (Rmt)
- Ten speeds with speed indicator LEDs on front panel of unit, up to 50Mbps @ about 300meters (984ft.), down to 1Mbps @ about 1,900meters (6,233ft.)
- Operating voltage and Max. current consumption: 0.225A @ 12VDC, 0.113A @ 24VDC. Power consumption: 2.7W Max.
- Power Supply: Redundant 12-30VDC Terminal Block power inputs and 12VDC DC JACK with 100-240VAC external power supply
- Operating temperature ranges from -34°C to 74°C
- Supports Din-Rail, Panel, or Rack Mounting installation

Packing List

When you unpack this product package, you will find the items listed below. Please inspect the contents, and report any apparent damage or missing items immediately to our authorized reseller.

The Hardened VDSL Ethernet Extender

USER'S MANUAL

AC to DC Power Adaptor and Power Cable (optional)

One-Channel Hardened VDSL Ethernet Extender

Ports

The Hardened VDSL Ethernet Extender provides one TX port and one VDSL port. For the TX port, it uses RJ-45 connector and auto senses the speed of 10/100Mbps. For the VDSL port, it uses RJ-11 and Terminal Block connectors and auto senses the speed of 1/3/5/10/15/20/25/30/40/50Mbps.

VDSL Mode Settings

VDSL mode settings are made very simple by means of a DIP (Dual Inline Package) switch on the top panel of the Hardened VDSL Ethernet Extender.

DIP switch

There is one pin on the DIP switch for VDSL mode settings. Refer to the table below for more details.

Loc	Rmt
The device operates in local mode	The device operates in remote mode

Front Panel & LEDs

LED Indicators

The LED indicators give you instant feedback on status of the Hardened VDSL Ethernet Extender:

LEDs	State	Indication
Power 1	Steady	Power on
Power 2 Power 3	Off	Power off
Ethernet		
Link/ACT	Steady	A valid Ethernet connection established
	Flashing	Transmitting or receiving Ethernet data ACT stands for ACTIVITY
	Off	Neither valid Ethernet connection established nor transmitting/receiving Ethernet data
FDX	Steady	Ethernet Connection in full-duplex mode FDX stands for FULL-DUPLEX
	Off	Ethernet Connection in half-duplex mode
Ethernet over VDSL		
1	Green	The VDSL port transmitting/receiving at 1Mbps, up to 1900M
	Amber	The VDSL port transmitting/receiving at 3Mbps, up to 1800M
2	Green	The VDSL port transmitting/receiving at 5Mbps, up to 1600M
	Amber	The VDSL port transmitting/receiving at 10Mbps, up to 1400M
3	Green	The VDSL port transmitting/receiving at 15Mbps, up to 1200M
	Amber	The VDSL port transmitting/receiving at 20Mbps, up to 1000M
4	Green	The VDSL port transmitting/receiving at 25Mbps, up to 800M
	Amber	The VDSL port transmitting/receiving at 30Mbps, up to 700M
5	Green	The VDSL port transmitting/receiving at 40Mbps, up to 600M
	Amber	The VDSL port transmitting/receiving at 50Mbps, up to 300M
Remote	Steady	The device operates in remote mode
Local	Steady	The device operates in local mode
Error	Steady	Error occurred
Link	Steady	A valid VDSL connection established

Installation

This chapter gives step-by-step installation instructions for the Hardened VDSL Ethernet Extender.

Selecting a Site for the Equipment

As with any electric device, you should place the equipment where it will not be subjected to extreme temperatures, humidity, or electromagnetic interference. Specifically, the site you select should meet the following requirements:

- The ambient temperature should be between -34 to 74 degrees Celsius.
- The relative humidity should be less than 95 percent, non-condensing.
- Surrounding electrical devices should not exceed the electromagnetic field (RF) standards.
- Make sure that the equipment receives adequate ventilation. Do not block the ventilation holes of the equipment.
- The power outlet should be within 1.8 meters of the product.

DIN Rail Mounting

Fix the DIN rail attachment plate to the back panel of the Hardened VDSL Ethernet Extender.

Installation: Place the Hardened VDSL Ethernet Extender on the DIN rail from above using the slot. Push the front of the Hardened VDSL Ethernet Extender toward the mounting surface until it audibly snaps into place.

Removal: Pull out the lower edge and then remove the Hardened VDSL Ethernet Extender from the DIN rail.

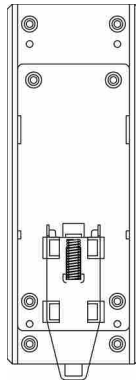

Connecting to Power

Redundant DC Terminal Block Power Inputs or 12VDC DC Jack:

12VDC DC Jack

Step 1: Connect the supplied AC to DC power adapter to the receptacle on the topside of the Hardened VDSL Ethernet Extender.

Step 2: Connect the power cord to the AC to DC power adapter and attach the plug into a standard AC outlet with the appropriate AC voltage.

Redundant DC Terminal Block Power Inputs

There are two pairs of power inputs can be used to power up this device. You only need to have one power input connected to run the Hardened VDSL Ethernet Extender.

Step 1: Connect the DC power cord to the plug-able terminal block on the Hardened VDSL Ethernet Extender, and then plug it into a standard DC outlet.

Step 2: Disconnect the power cord if you want to shut down the Hardened VDSL Ethernet Extender.

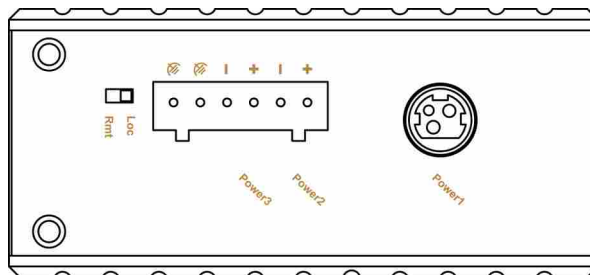

Power Input Assignment		
Power1		12VDC DC Jack
Power2	+	12-30VDC
	-	Power Ground
Power3	+	12-30VDC
	-	Power Ground
		Earth Ground
DIP Switch Assignment		
Loc	The device operates in local mode	
Rmt	The device operates in remote mode	

Specifications

Applicable Standards	IEEE802.3 10Base-T IEEE802.3u 100Base-TX Ethernet over VDSL
Fixed Ports	1 x 10/100Mbps Ethernet port with RJ-45 connector 1 x Ethernet over VDSL port with RJ-11 and Terminal Block connectors
Speed 10Base-T 100Base-TX Ethernet over VDSL	10/20Mbps for half/full-duplex 100/200Mbps for half/full-duplex 1, 3, 5, 10, 15, 20, 25, 30, 40, 50Mbps
Switching Method	Store-and-Forward
Forwarding rate	14,880/148,810pps for 10/100Mbps
Cable 10Base-T 100Base-TX Ethernet over VDSL	2-pair UTP/STP Cat. 3, 4, 5 up to 100m 2-pair UTP/STP Cat. 5 up to 100m Cross-over telephone wires
LED Indicators	Per Unit (3 LEDs)- Power1, Power2, Power3 Per Port- RJ-45 (2 LEDs): Link/ACT, FDX RJ-11, Terminal Block (9 LEDs): Remote, Local, Error, Link, 1, 2, 3, 4, 5
Dimensions	50mm (W) x 110mm (D) x 136mm (H) (1.97" (W) x 4.33" (D) x 5.35" (H))
Weight	0.8Kg (1.76lbs.)
Power	Terminal Block: 12-30VDC DC Jack: 12VDC, External AC/DC required
Operating Voltage & Max. Current Consumption	0.225A @ 12VDC, 0.113A @ 24VDC
Power Consumption	2.7W Max.
Operating Temperature	-34°C ~ 74°C (-29°F ~ 165°F)
Storage Temperature	-40°C ~ 85°C (-40°F ~ 185°F)
Humidity	10 ~ 95%, non-condensing
Safety	UL60950, EN60950, IEC60950
Emissions	FCC Part 15, Class A CE: EN61000-6-2 EN61000-6-3

Standards
ESD Standard (EN61000-4-2)
Radiated FRI Standards (EN61000-4-3)
Burst Standards (EN61000-4-4)
Surge Standards (EN61000-4-5)
Induced RFI Standards (EN61000-4-6)
Magnetic Field Standards (EN61000-4-8)
Voltage Dips Standards (EN61000-4-11)
Environmental Test Compliance: Vibration Resistance (IEC60068-2-6) Shock (IEC60068-2-27) Free Fall (IEC60068-2-32)
NEMA TS1/2 Environmental requirements for traffic control equipment

MICROSENS reserves the right to make any changes without further notice to any product to improve reliability, function or design. MICROSENS does not assume any liability arising out of the application or use of any product. FR 1708