

# Fast Ethernet switch for industrial ring application with integrated PoE function

# MICROSENS

## General

Ethernet has been used in the controlling level of industrial applications for many years. Ethernet is continuing to beat the field bus technologies used to date in coupling equipment controls, sensors and actors. Process error-tolerant network components are absolutely essential because the network availability has a direct effect on production.

It is precisely to prevent this that MICROSENS has developed a mechanism for which a patent is pending that enables the Ethernet network to be reconfigured within milliseconds if an error occurs.

The switches can be configured and monitored either by SNMP or a PC-based management tool (Device Manager). In addition to the Device Manager all statuses are displayed web based using an integrated HTTP server.

In addition to the two 100Base-FX fiber connections for chain linking several industrial switches, the MICROSENS industrial switches also offer four 10/100Base-TX connections for linking such Ethernet terminals as machine controls, network uplinks, consoles and other network participants.

For particularly demanding uses, the industrial switches are designed in a suitably robust construction with an integrated clamping device for direct assembly on 35 mm DIN rails. The devices meet the requirements for IP protection class 20 and are also designed for a larger temperature range.

The power supply of the devices is done by an external, central power supply unit. With the second power input the device can be supplied with redundant power. All electrical ports are either galvanic isolated or equipped with an effective over voltage protection.

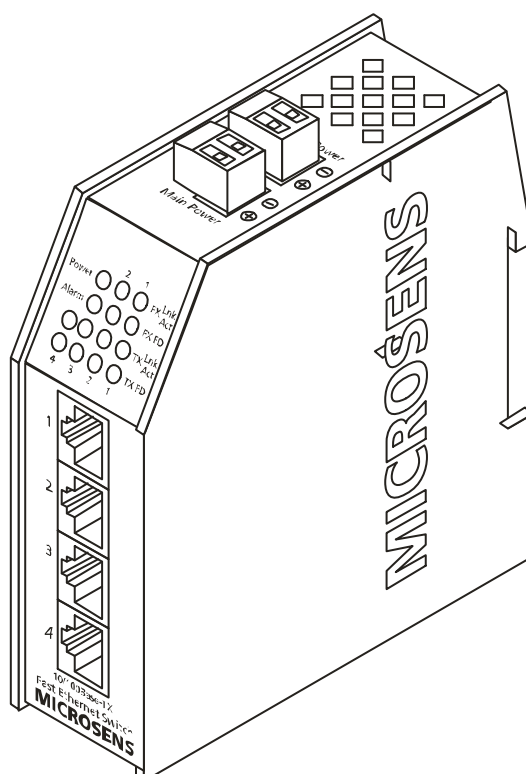

## Technical specifications

<b>Type</b>	Manageable Fast Ethernet switch with 4 x 10/100Base-TX and 2 x 100Base-FX uplink for industrial fiber ring with PoE function	
<b>Fiber type</b>	Multimode 62,5/125 or 50/125µm, Single mode 9/125µm, duplex	
<b>Cable type</b>	Shielded Twisted Pair cable, 100 Ohm, Category 5, Pinout RJ45-ports auto crossing	
<b>Data rate</b>	10 or 100 Mbit/s	
<b>LED displays</b>	<i>Power</i>	Ready for operation
	<i>Link</i>	Link status each port
	<i>Act</i>	Data traffic each port
	<i>FDX/HDX</i>	Half or full duplex transmission each port
	<i>Alarm</i>	Fiber link interrupted
<b>Mounting</b>	35 mm hat rail, according DIN EN 50 022	
<b>Power supply</b>	48 V DC / max. 1.35 A by external power supply connections with screw terminals, redundant ports	
<b>Dimensions</b>	38 x 108 x 116 mm (w x d x h)	
<b>Operating temperature</b>	-20°C to 60°C	
<b>Storage temperature</b>	-20°C to 80°C	
<b>Rel. humidity</b>	5% to 90% non condensing	
<b>Management</b>	<ul style="list-style-type: none"> <li>- Status information via web based management (http-Server) or support of SNMPv1</li> <li>- Configuration via PC based management tool (Device Manager)</li> </ul>	

## Optical parameter

<b>Multimode</b>	<i>min. distance:</i>	2 km (full duplex)
	<i>Output power:</i>	-19 dBm
	<i>Sensitivity:</i>	-31 dBm
	<i>Wavelength:</i>	1300 nm
<b>Single mode</b>	<i>min. distance:</i>	15 km (full duplex)
	<i>Output power:</i>	- 15 dBm
	<i>Sensitivity:</i>	- 31 dBm
	<i>Wavelength:</i>	1300 nm

## Mounting

The switch is housed in a solid metal box with an integrated fixture for the installation on standard 35 mm DIN EN 50 022 rails.

The fixation of the MICROSENS switch on the rail is done with a locking pin that can be opened from the bottom side. If multiple devices are mounted in line, a minimum space of 20 mm should be kept between the devices, to ensure a sufficient heat dissipation.

## Connectors

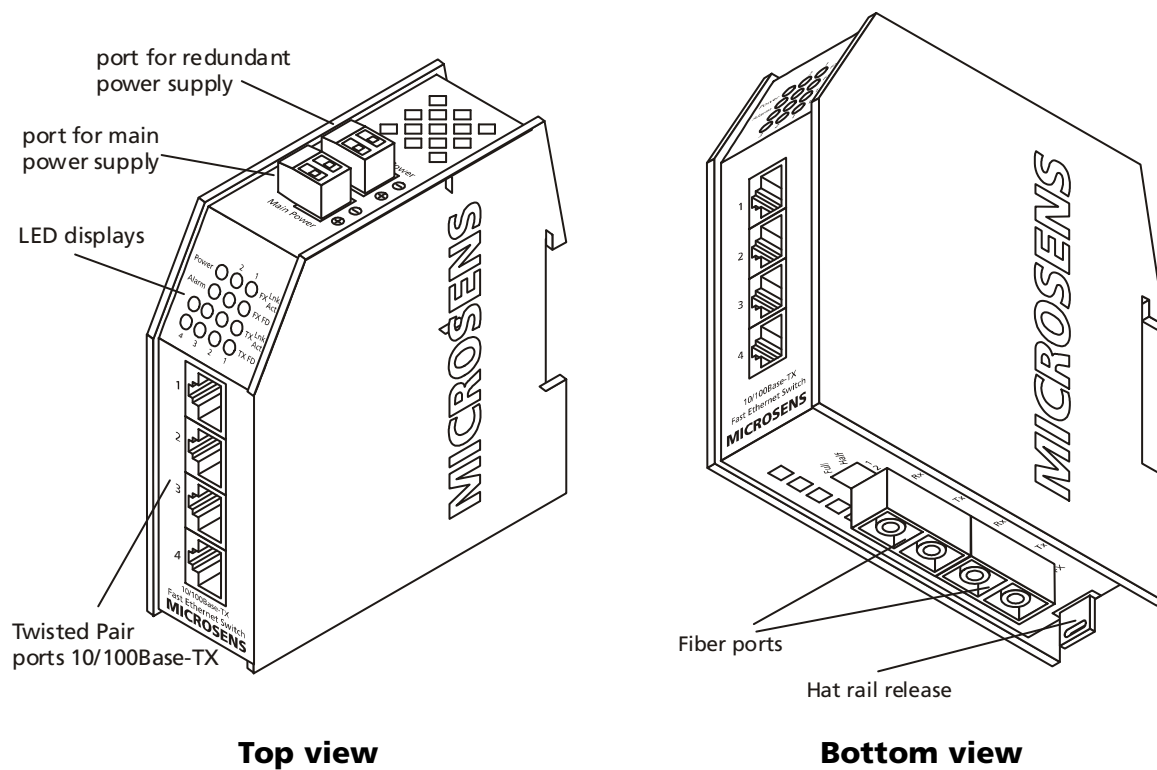

**Top view**

**Bottom view**

## Switch Features

The integrated switch has a store-and-forward architecture and can transmit all packets non-blocking between the five ports at full wire speed. For data buffering the switch incorporates 1MB of memory.

Up to 4096 different MAC addresses can be stored simultaneously in the internal switch address tables. An automatic aging mechanism updates the tables max. 10 min. after the last reception of data.

## Twisted Pair Connections

The integrated auto-crossing function of all Twisted-Pair ports makes the use of crossed patch cables unnecessary. The switch automatically detects the pinout of the connected cable and adapts the port accordingly. For all connections standard 1:1 Twisted Pair cables can be used.

The Autonegotiation mechanism detects automatically the speed and transmission mode (full or half duplex) between connected ports. A manual configuration is not required.

## Power supply

The power supply is done by an external power supply with an output voltage of 24 V DC. This power supply is not included at delivery, but can be ordered separately (MS700420). The connection is done by the pluggable screw terminals on the top of the device. The connection of a redundant power supply can be done by the second screw terminal.

## Management

The integrated http server offers to show status information by using a standard internet browser. A special configuration is not necessary. Additional to the web based management the switch offers a MIB to be used in all standardized Network Management Systems (NMS) supporting SNMPv1 protocol.

With the PC based management tool Device Manager it is possible to configure all ports of the switch manually. Please refer to the online manual for the Device manager on the disk.

With this tool it is also possible to do the initial TCP/IP setting (IP address, Gateway etc.). This configuration can be changed afterwards using the TCP/IP protocol.

**Attention:** The description for the initial settings can be found in the online manual!

The management information are available inside of the network (inband management). A special connection is not necessary. Due to this all four twisted pair ports are available to connect other devices.

With the deactivation of the autonegotiation function of the twisted pair ports the configuration of the speed to 10 or 100 Mbit/s and full or half duplex mode is done manually.

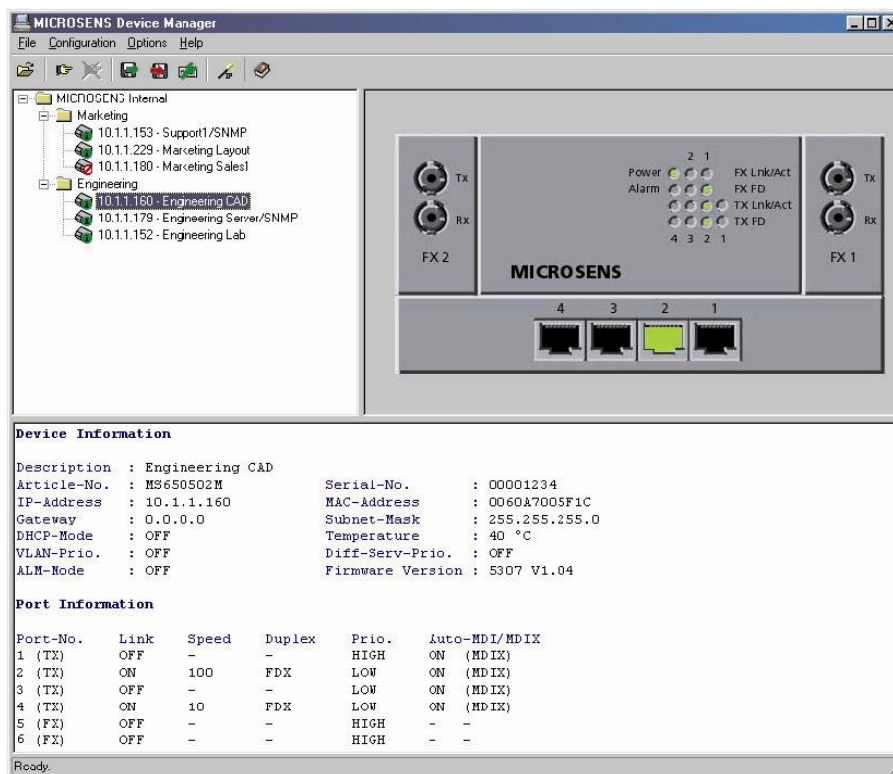

MICROSENS Device Manager

## Dimensions

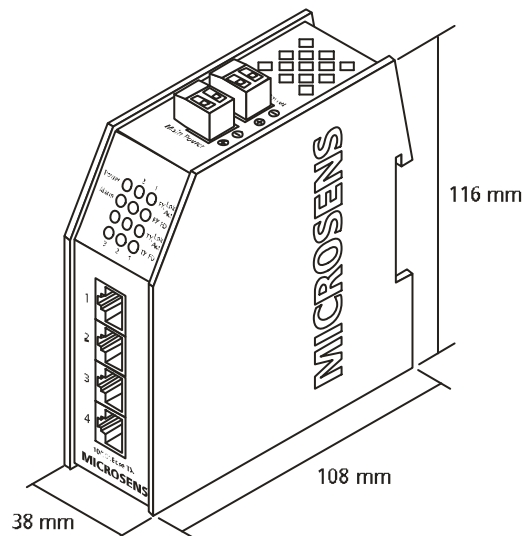

## Ring Function

The two fiber ports of the device can be used to build up a ring structure. Ring structures are commonly used in industrial and telecommunication environments as they give redundant protection against failures at minimum cabling expense.

In normal operation the ring connection is logically interrupted by monitoring device (switch configured for Ring Master mode). In case of failure (broken connection or switch damage) the logically interrupted connection is activated by Ring Master.

A big advantage of this solution is, that no additional central device is necessary for the redundancy feature. Even if the ring master itself fails, the interruption of the ring stays at this location.

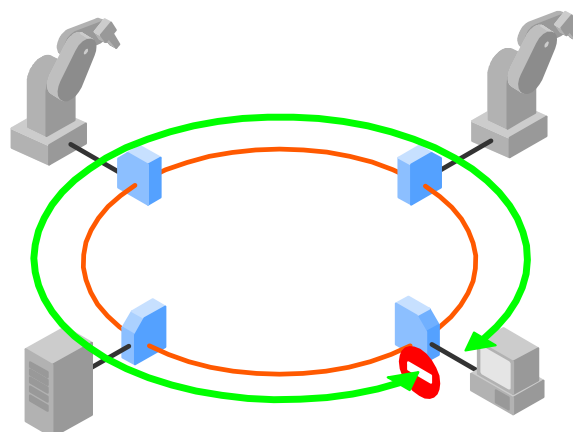

Normal operation status

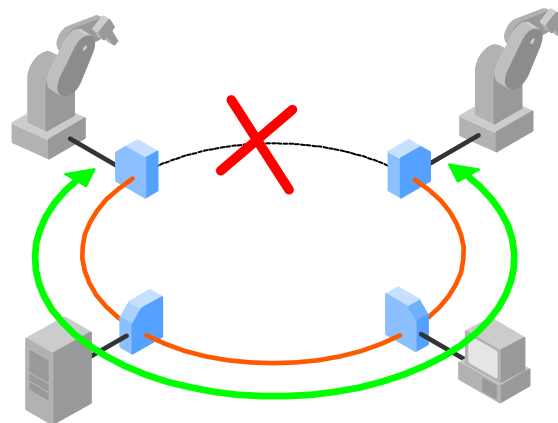

Data transmission in failure status

## Ring Mechanism

The from MICROSENS patented protection mechanism supports the fast reconfiguration of the data transmission in case of failure of one fiber segment. This function is a fixed feature of the industrial switch. During this operation one switch is having the manager function, all other switches are normal ring switches.

Each switch is monitoring the status of the connected fiber segment. In case of failure the connected switch forwards this information to the ring manager. The ring manager terminates the interruption of the ring immediately. The data is transmitted in all directions then. This fast signaling a fast failure detection within a few milliseconds (depending on the ring size).

## Ring Configuration

The configuration of the operating mode for the ring application is done with the network management.

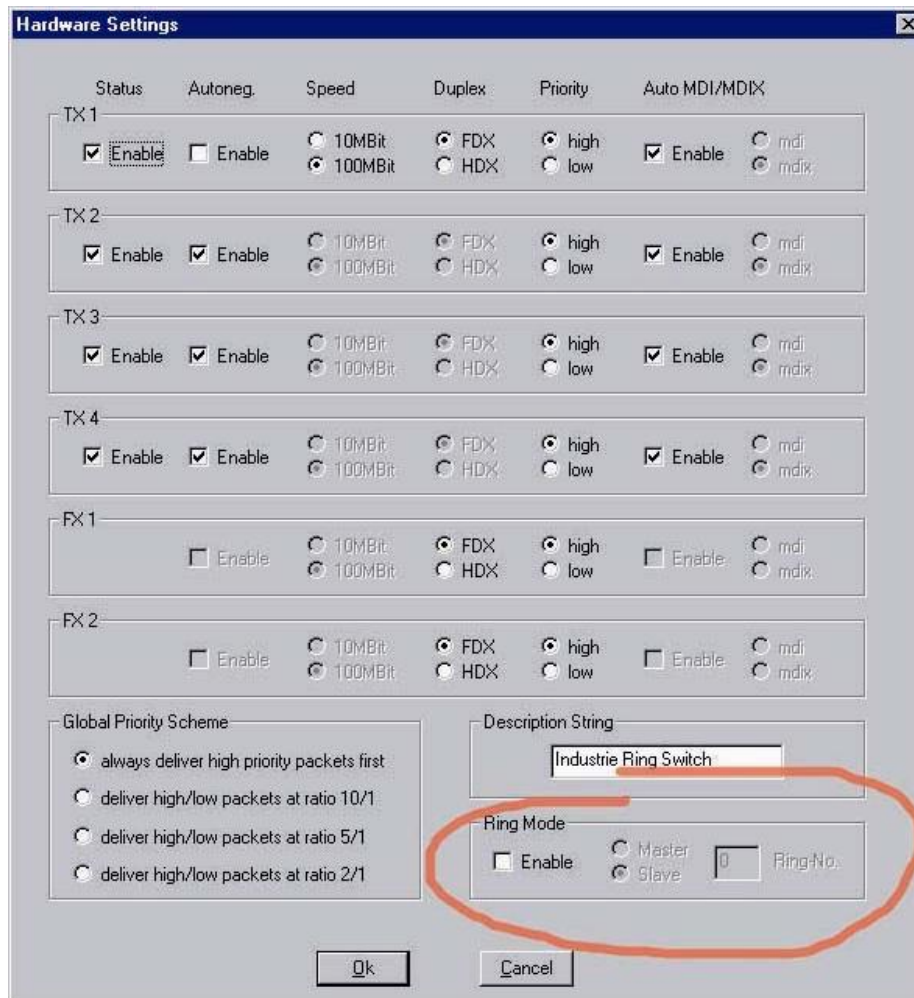

At the menu point Hardware Setting it is possible to select the two modes master or slave. The switch which is configured in master mode is doing the ring manager functions to avoid the multiplication of the data.

If one connection or one device fails this information is forwarded to the ring manager (master) by a special protocol. The ring manager keeps the operation of the complete segment up.

Advantage of this solution is that the ring manager itself has not to be redundant, because if the manager fails the data can not be multiplied. The segments stays under operation.

To avoid that the signaling in case of failure has no affect on other rings, it is possible to define different rings with numbers from 0 to 255 by the network management.

All switches with ring functionality are having the management features included and are offering the detection and signaling of any failure.

With this concept a limitation in regards to the maximum ring length is not given.

## Transmission Speed

The twisted pair ports of the switch are adapting automatically to the highest possible speed using the autonegotiation protocol. The LED displays are showing the selected speed. If necessary this configuration can be also done by the network management.

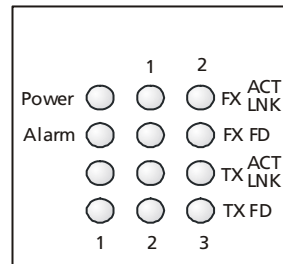

The transmission in full duplex mode is indicated by the related LED (on). If the connection is working in half duplex mode, this LED indicates collisions for the connected segment (flashing).

The transmission mode of the fiber uplinks are selected by the network management. Important is that distances longer than 412 m can be realized only in full duplex mode. The duplex settings are independent from the mode of the ring feature.

## Power-over-Ethernet

The fast Ethernet Ring Switch supports the Power-over-Ethernet function and supplies the 48VDC to devices such as IP phones, wireless access points, Web cameras, access control systems via twisted-pair cables.

The Power-over-Ethernet functionality according to the new IEEE802.3af standard is integrated into the Industrial Switch. The standard defines the functions of both the Power Sourcing Equipment (PSE) and of the Powered Device (PD). A handshake protocol between PSE and PD negotiates the current supply where several levels are possible.

Each of the 4 TP-ports can supply the 48VDC in addition to the data. The power is supplied according to the IEEE 802.3af standard via the unused wires of the RJ45 socket (wire 4 and 5: positive line, wire 7 and 8: negative line).

The switch is designed for a total power consumption of 60 W. This offers a total power of approx. 52 W which can be supplied to the end devices. The PoE Fast Ethernet Switch controls the PoE DC supply with its microprocessor controlled Power Management as specified in the 802.3af standard.

To protect non PoE capable end devices the supply voltage is switched on only after getting a valid PoE signature from the end device. Furthermore the power consumption is monitored permanent. If the limits are passed, the power supply is switched off immediately.

## **Safety Notes**

**WARNING:** Infrared radiation as used for data transmission within the fiber optic, although invisible to the human eye, can nevertheless cause damage.

To avoid damage to the eyes:

- never look straight into the output of fiber optic components – danger of blinding!
- cover all unused optical connections with caps.
- commission the transmission link only after completing all connections.

The active laser components used with this product comply with the provisions of **Laser Class 1**.

**DANGER:** Conductive components of power and telecommunications networks can carry dangerously high voltage.

To avoid electric shock:

- Do not carry out installation or maintenance work during lightning storms.
- All electric installations must be carried out in accordance with local regulations.

## Order Information

Art.-No.	Description	Connectors
MS650501PM-48	Fast Ethernet Switch with ring function 4x 10/100Base-TX, 2x 100Base-FX ST multimode 1310 nm	4x ST 4x RJ45 2x power input
MS650502PM-48	Fast Ethernet Switch with ring function 4x 10/100Base-TX, 2x 100Base-FX SC multimode 1310 nm	2x SC duplex 4x RJ45 2x power input
MS650504PM-48	Fast Ethernet Switch with ring function 4x 10/100Base-TX, 2x 100Base-FX SC single mode 1310 nm	2x SC duplex 4x RJ45 2x power input
MS650505PM-48	Fast Ethernet Switch with ring function 4x 10/100Base-TX, 2x 100Base-FX ST single mode 1310 nm	4x ST 4x RJ45 2x power input
MS650506PM-48	Fast Ethernet Switch with ring function 4x 10/100Base-TX, 2x 100Base-FX SC single mode 1310 nm, 2x 40 km	2x SC duplex 4x RJ45 2x power input
MS650507PM-48	Fast Ethernet Switch with ring function 4x 10/100Base-TX, 2x 100Base-FX ST single mode 1310 nm, 2x 40 km	2x ST duplex 4x RJ45 2x power input
MS650507PM-48	Fast Ethernet Switch with ring function 4x 10/100Base-TX, 2x 100Base-FX SC single mode 1310 nm, 1x 15 km + 2x 40 km	1x SC duplex 15 km 1x SC duplex 40 km 4x RJ45 2x power input

**Accessories**

<b>Art.-Nr.</b>	<b>Description</b>	<b>Connectors</b>
MS200150	Device Manager PC-Software V3.x MICROSENS Switch-Management (necessary for Ring Configuration)	
MS700420	Hat-rail power supply 24 Watt 24 V / 1.0 A, wide range input 85-264 VAC	In: 3-pin Out: 2-pin
MS700421	Hat-rail power supply 60 Watt 24 V / 2.5 A, wide range input 85-264 VAC	In: 3-pin Out: 5-pin
MS700422	Hat-rail power supply 120 Watt 24 V / 5.0 A, wide range input 85-264 VAC	In: 3-pin Out: 5-pin
MS700430	Hat-rail power supply 60 Watt 48 V / 1.25 A, wide range input 85-264 VAC	In: 3-pin Out: 5-pin

MICROSENS reserves the right to make any changes without further notice to any product to improve reliability, function or design. MICROSENS does not assume any liability arising out of the application or use of any product. 2603/He/18/06fr

[www.microsens.com](http://www.microsens.com)